

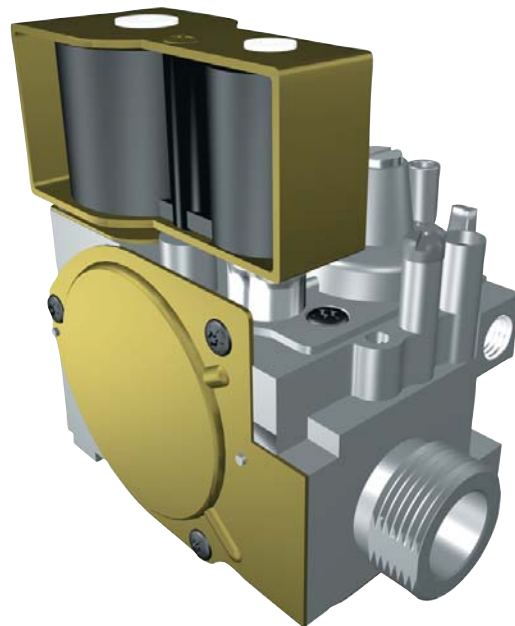

SITGroup

848 SIGMA



MULTIFUNCTIONAL 1:1 GAS/AIR CONTROL FOR GAS BURNING APPLIANCE

Application

Domestic fan assisted gas appliances. 848 SIGMA is particularly suitable for premix gas burners.

Main features

Two shut off valves.
1:1 gas/air ratio.
Gas/air adjuster on request.

Normative Reference

EN 126
Multifunctional devices for gas burning appliances.

EN 12067-1
Gas/air ratio controls for gas burners and gas burning appliances.



VALVE DESCRIPTION

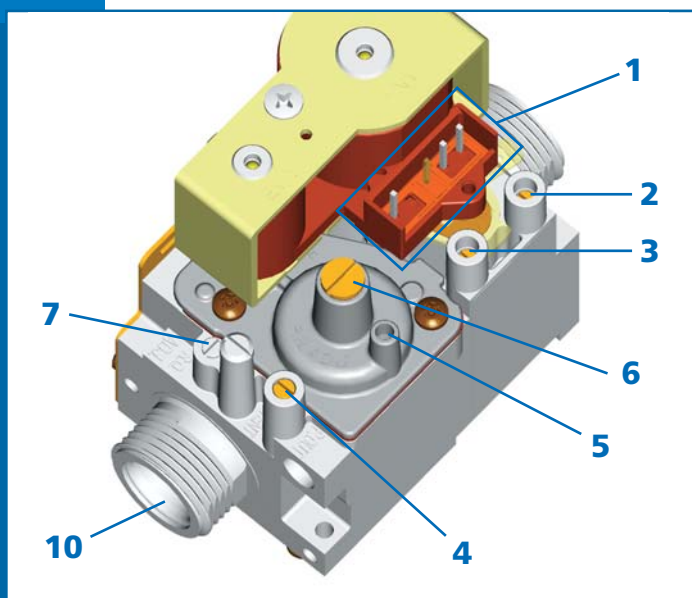

Fig. 1

It consists of two automatic shut-off valves in series in the main gas path, a pressure regulator and a 1:1 gas/air pressure ratio modulator. The pilot outlet (optional) is located downstream the first valve.

With reference to the schematic blocks in Fig. 1:

- FL is the inlet filter.
- EV1 is a direct acting automatic shut-off valve.
- FLP is the pilot filter.
- RP is a servo pressure regulator, adjustable by a screw.
- G/A is the pneumatic device for the control of the gas pressure according to the air pressure signal.
- EV2 is the second direct acting automatic shut-off valve.
- RQ is a gas/air ratio adjuster (optional).



- 1 On-Off solenoid valves EV1 and EV2 terminals
- 2 Inlet pressure test point
- 3 Outlet pressure test point P_{INT}
- 4 Additional outlet pressure test point P_{OUT} (version with gas/air adjuster)
- 5 Air signal connection
- 6 Zero adjustment (offset)
- 7 Gas/air ratio adjuster (optional)
- 8 Gas inlet
- 9 Pilot outlet (optional)
- 10 Main gas outlet
- 11 Side outlet (optional)
- 12 Mounting holes

Version with side outlet

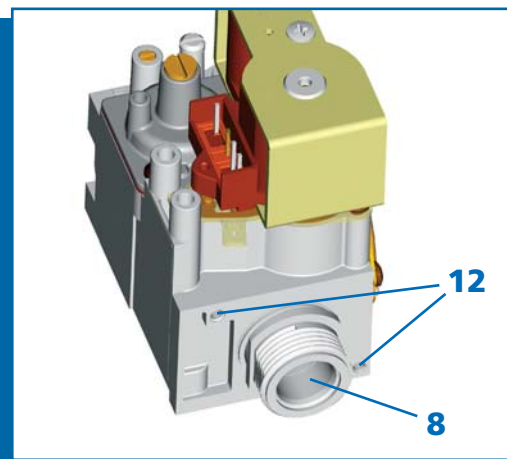
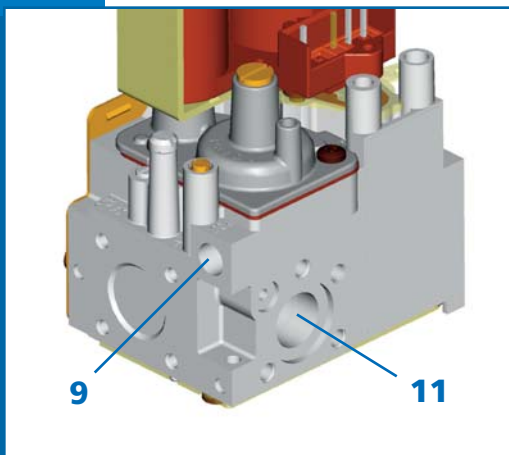

GENERAL DATA

CONSTRUCTION CHARACTERISTICS

- Aluminium alloy body
- Two shut-off valves
- Inline inlet and outlet
- Side outlet (optional)
- Inlet filter
- Pilot outlet (optional)
- Outlet and pilot filters (optionals)
- Inlet pressure test point
- Outlet pressure test point P_{INT}
- Additional outlet pressure test point P_{OUT} (version with gas/air adjuster)
- Air signal connection
- Two mounting holes

USE SPECIFICATIONS

- Inlet filter 195 µm mesh
- Mounting position any
- Gas families II and III
- Ambient temperature 0...60 °C
- Maximum inlet pressure 60 mbar
- Maximum pressure drop P_{INT}-P_a with closed shut off valves (pre-purge or other conditions) -12...+12 mbar
- Minimum gas flow 0.5 m³/h for 2nd family gas (group H/L/E)
0.3 m³/h for 3rd family gas (LPG)
- Bending and torsion resistance Group 2

MECHANICAL CONNECTIONS

- Gas inlet and outlet G 3/4 B ISO 228
or: M4 (4) (flanges)
minimum full thread 6 mm
or: Rp 1/2 ISO 7 (105 mm version)
- Side outlet (optional) M5 (3)
- Pilot (optional) M10x1 for tube ø4 , ø6 mm or ø1/4"
- Pressure test point ø9 mm
- Air signal connection ø7 mm
- Mounting holes M4 x 6.5 mm



ELECTRICAL DATA

AUTOMATIC SHUT OFF VALVES:	EV1	EV2	EV1	EV2
Nominal supply voltage (AC)	Current at nominal voltage (mA)		Power at nominal voltage (W)	
230 V 50 Hz	40	12	4.3	2.0
24 V 50 Hz	390	100	4.6	2.0
220 V 60 Hz	48	20	5.5	2.9
24 V 60 Hz	480	120	6.0	1.8
24 V RAC	270	115	6.5	2.8

ELECTRICAL CONNECTION

- Automatic shut off valves
- Protection degree

Male contact 3003 Molex compatible, suitable for female Molex series 3001

IP 40 with SIT connectors

IP 44 with SIT connectors and gasket

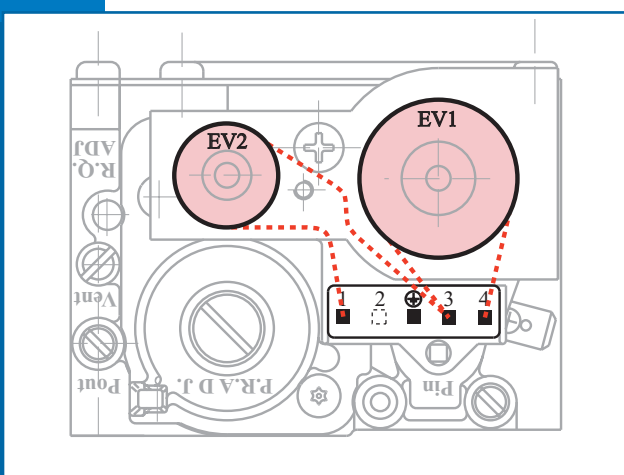

Fig. 2: connection diagram.

The connection diagram is given in Fig. 2. The automatic shut-off valve EV1 can be supplied connecting pins 3 and 4.

The automatic shut-off valve EV2 can be supplied connecting pins 1 and 3.

FUNCTIONS

AUTOMATIC SHUT-OFF

- Automatic shut-off valves closing time ≤ 1 s
- Automatic shut-off valve EV1 Class A or B
- Automatic shut-off valve EV2 Class C or J

GAS/AIR REGULATION

- Pressure drop range across gas injector ($P_{INT}-P_c$): 0.5...12 mbar
- Zero adjustment range (offset) ($P_{INT}-P_a$): -0.3...+0.3 mbar

PRESSURE REGULATION

- Servo pressure regulator class B (with reference to EN126)

CAPACITY

REGULATED FLOW RATE Q

Solenoid valves class B+J or B+C

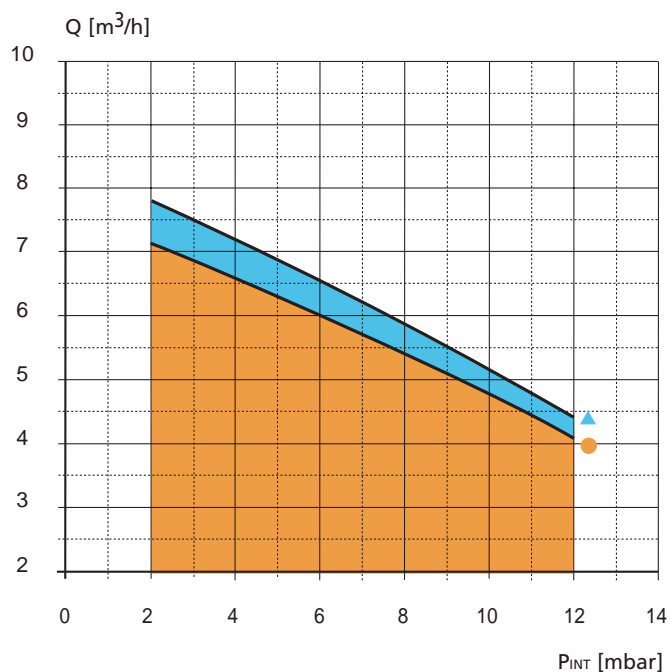

Second Family Group H

Inlet pressure range			
Nominal	Max.	Min.	Relative Density
20	25	17	0.555

- ▲ Version without ratio adjuster
- Version with ratio adjuster (ratio adjuster full open)

Solenoid valves class B+J or B+C

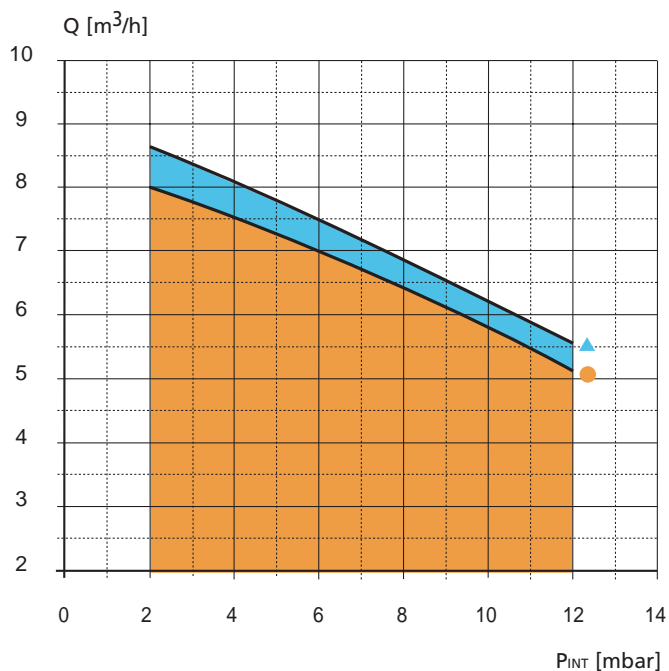

Second Family Group L

Inlet pressure range			
Nominal	Max.	Min.	Relative Density
25	30	20	0.612

- ▲ Version without ratio adjuster
- Version with ratio adjuster (ratio adjuster full open)



FUNCTIONAL DESCRIPTION

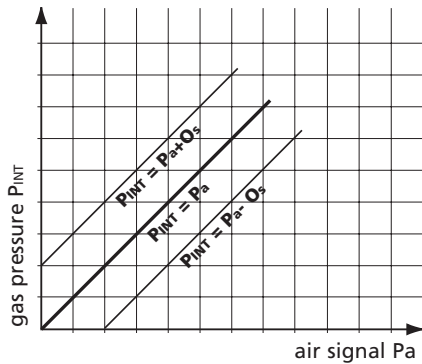

Fig. 3: Gas pressure/air ratio for different offset regulations

848 SIGMA has two automatic shut-off valves. When both of them are de-energised, it is only possible to measure the inlet pressure on the inlet pressure test point. When the solenoid EV1 is energised the first gas valve opens. The pilot outlet is enabled. Energising the second solenoid EV2, the second valve also opens and the gas flows through the main outlet. It is possible to measure the outlet pressure on the outlet pressure test point.

848 SIGMA is a 1:1 gas/air pressure ratio gas control.

The operation principle consists of keeping the outlet pressure P_{INT} , equal to the air pressure signal which can be increased or decreased according to the value chosen on the offset:

$$P_{INT} = P_a + O_s$$

O_s is the offset value that can be set by a screw.

The relation is represented in the P_a/P_{INT} graph (Fig.3).

When the offset value is set to zero and assuming the relation of volumetric flow/pressure drop is similar for air and gas, the gas/air ratio is kept constant despite any variation of P_a .

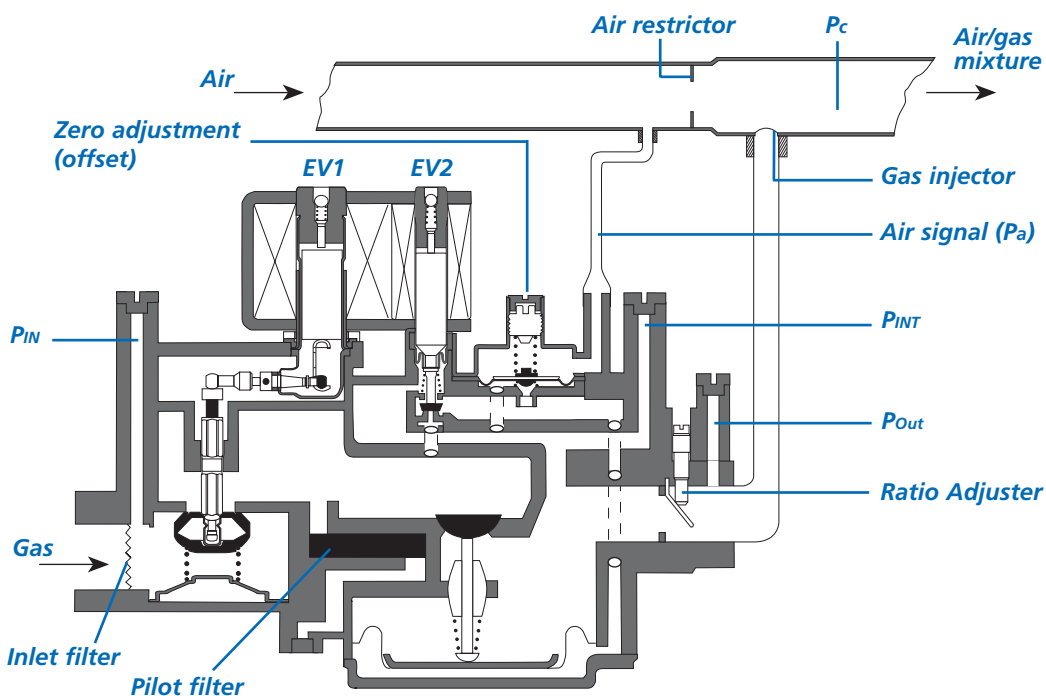

In other terms, the Q_g/Q_a ratio is constant for any value of air signal P_a , where Q_g and Q_a are rate of flow of gas and rate of flow of air respectively.

NOMENCLATURE

P_a	Air signal pressure.	$P_a - P_c$	Pressure drop across air restrictor.
P_c	Mixing chamber pressure.	$P_{INT} - P_a$	Pressure difference between outlet P_{INT} gas pressure and air signal.
P_{IN}	Inlet gas pressure.		
P_{INT}	Outlet pressure test point.		
P_{OUT}	Additional outlet pressure test point (version with gas/air ratio adjuster).		
			During operating conditions (gas valves open), it is called "offset".

SETTINGS AND ADJUSTMENTS

Versions with zero adjuster (offset)

All adjustments must be carried out in the following order. Check the inlet and outlet pressure using the pressure test points provided (A and B respectively). Remove the plug C.

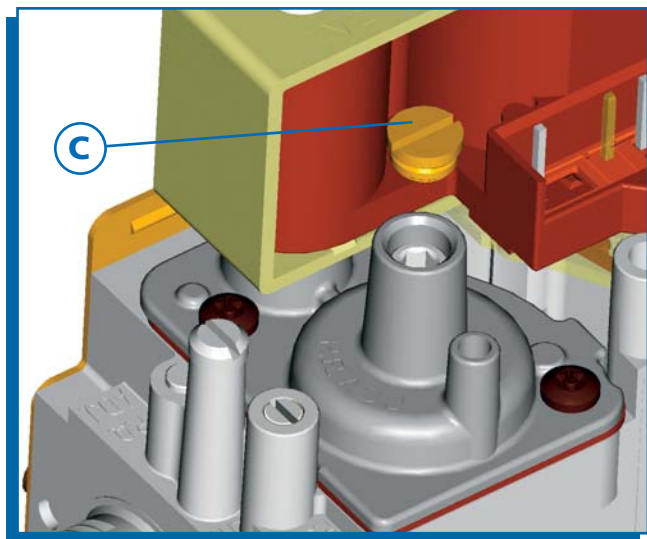

Reduce air signal P_a to the minimum and adjust the zero according to appliance specifications using screw D. Screw in to increase P_{INT} . After setting put back the protective plug C.

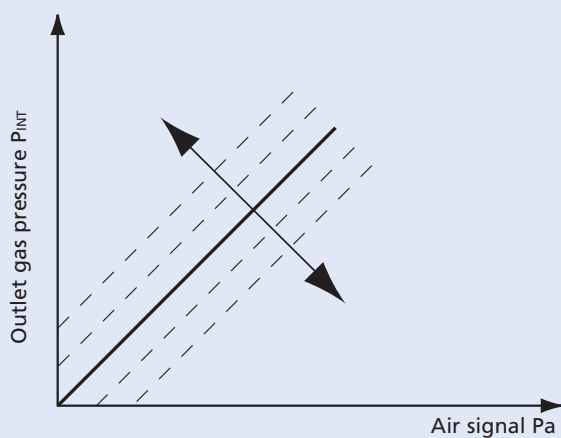
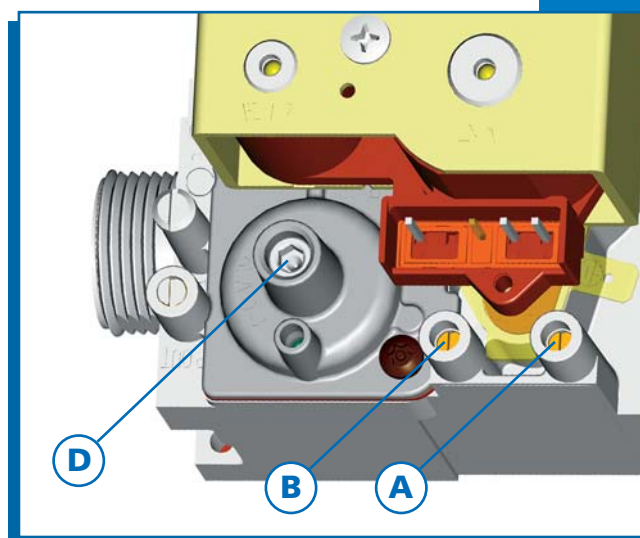



SETTINGS AND ADJUSTMENTS

Versions with zero (offset) and gas/air ratio adjustment

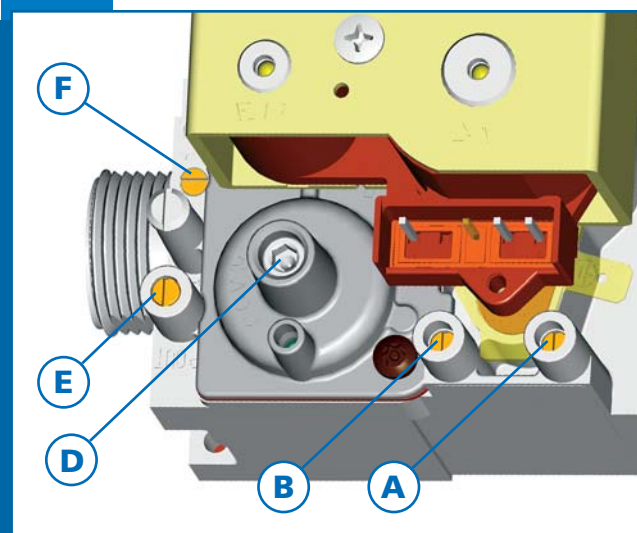
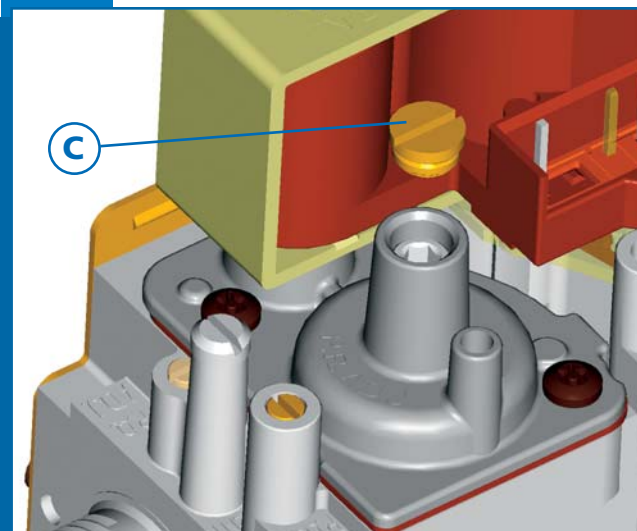

All adjustments must be carried out in the following order.

Check the inlet, intermediate, and outlet pressure using the pressure test points provided (A, B and E respectively). Remove the plug C.

Zero adjustment (offset)

Reduce air signal P_a to minimum required and move on to calibration of screw D in order to bring to the required value the difference CO_2 or the in pressure $P_{INT}-P_a$ where P_{INT} is measured on the intermediate test point B.

Screw in to increase the pressure P_{INT} .

Gas/air adjustment

Increase air value P_a to the maximum.

Regulate screw F to obtain combustion value required (CO_2), or to reach the required difference in pressure $P_{OUT}-P_c$, P_{OUT} must be measured on the outlet pressure test point E.

Screw in to decrease gas outlet pressure P_{OUT} .

Zero control (offset)

Reduce air to the minimum and if necessary proceed to a new regulation of $P_{INT}-P_a$.

After setting put back the protective plug C.

All the detailed guidelines for installation are given in the use and installation instructions code 9.956.848.

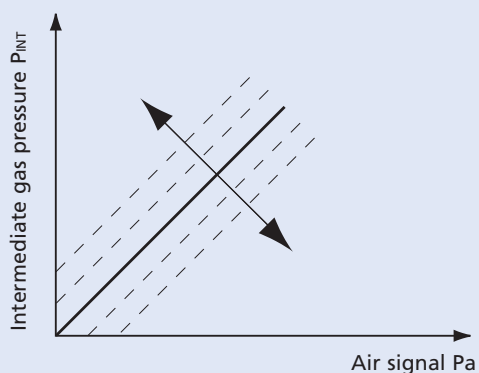

Zero adjustment (offset)

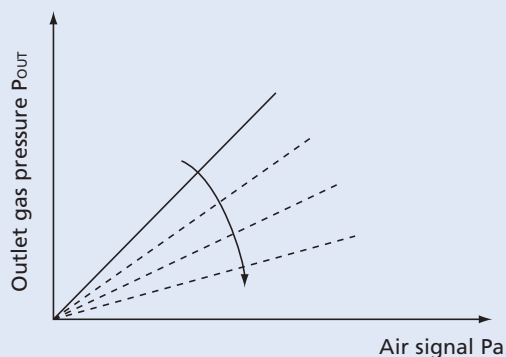

Gas/air ratio adjuster

DIMENSIONAL DRAWING

Gas connection: G 3/4 ISO 228

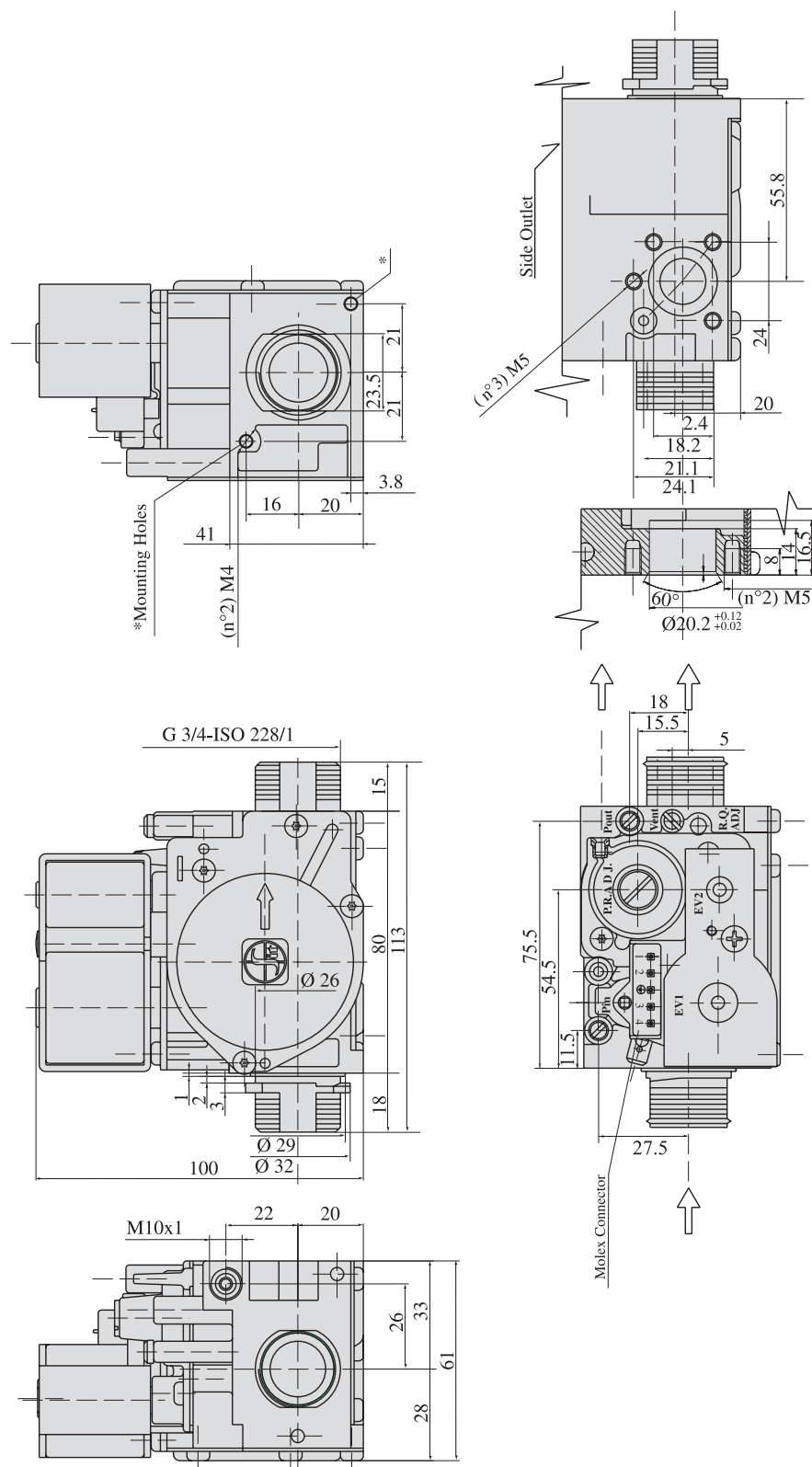

NOTE: All the dimensions are expressed in millimeters.



DIMENSIONAL DRAWING

Gas connection: flanges-80 mm version

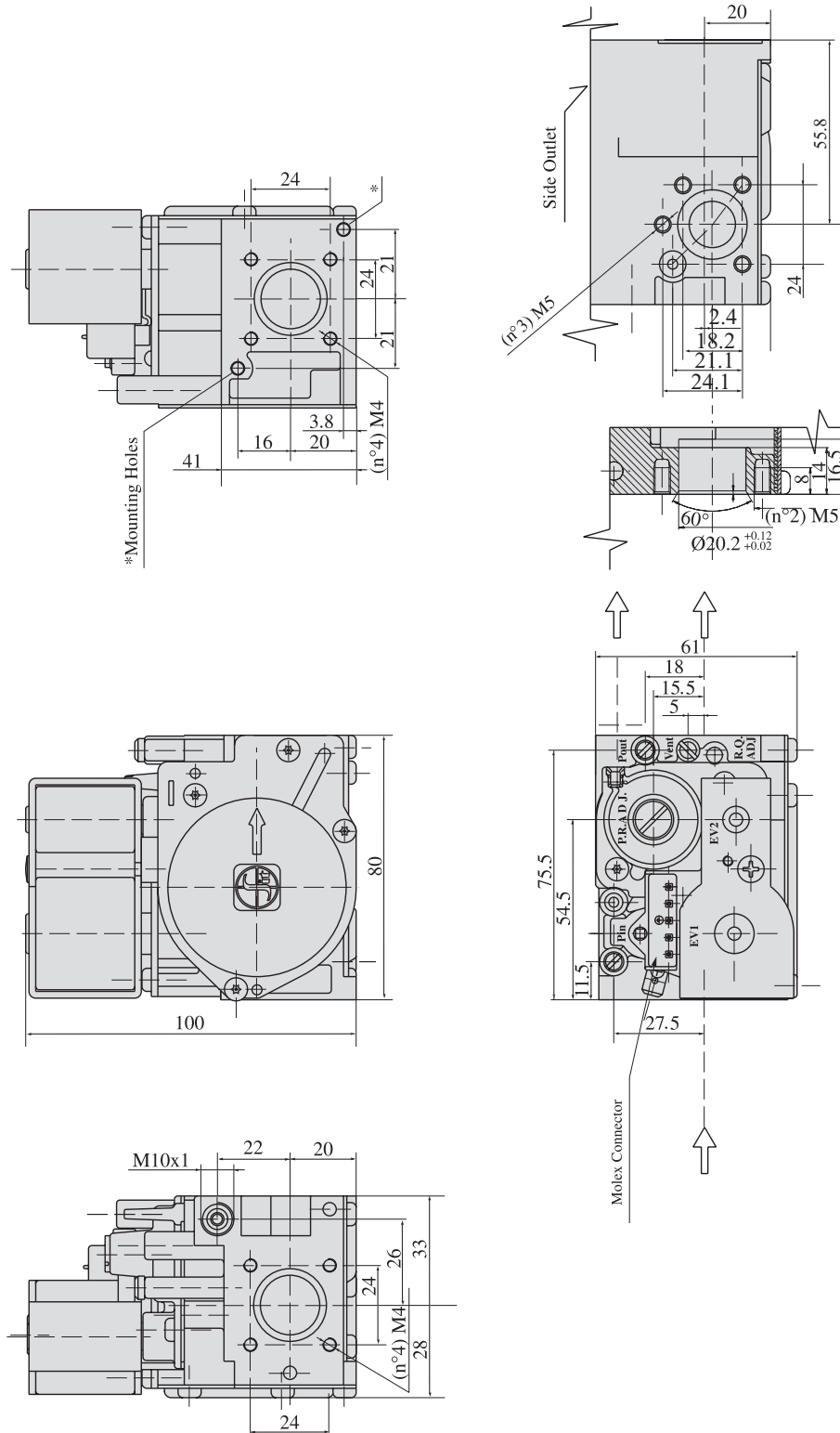

NOTE: All the dimensions are expressed in millimeters.

DIMENSIONAL DRAWING

Gas connection: flanges-105 mm version. Also available for Rp 1/2 ISO 7 connection

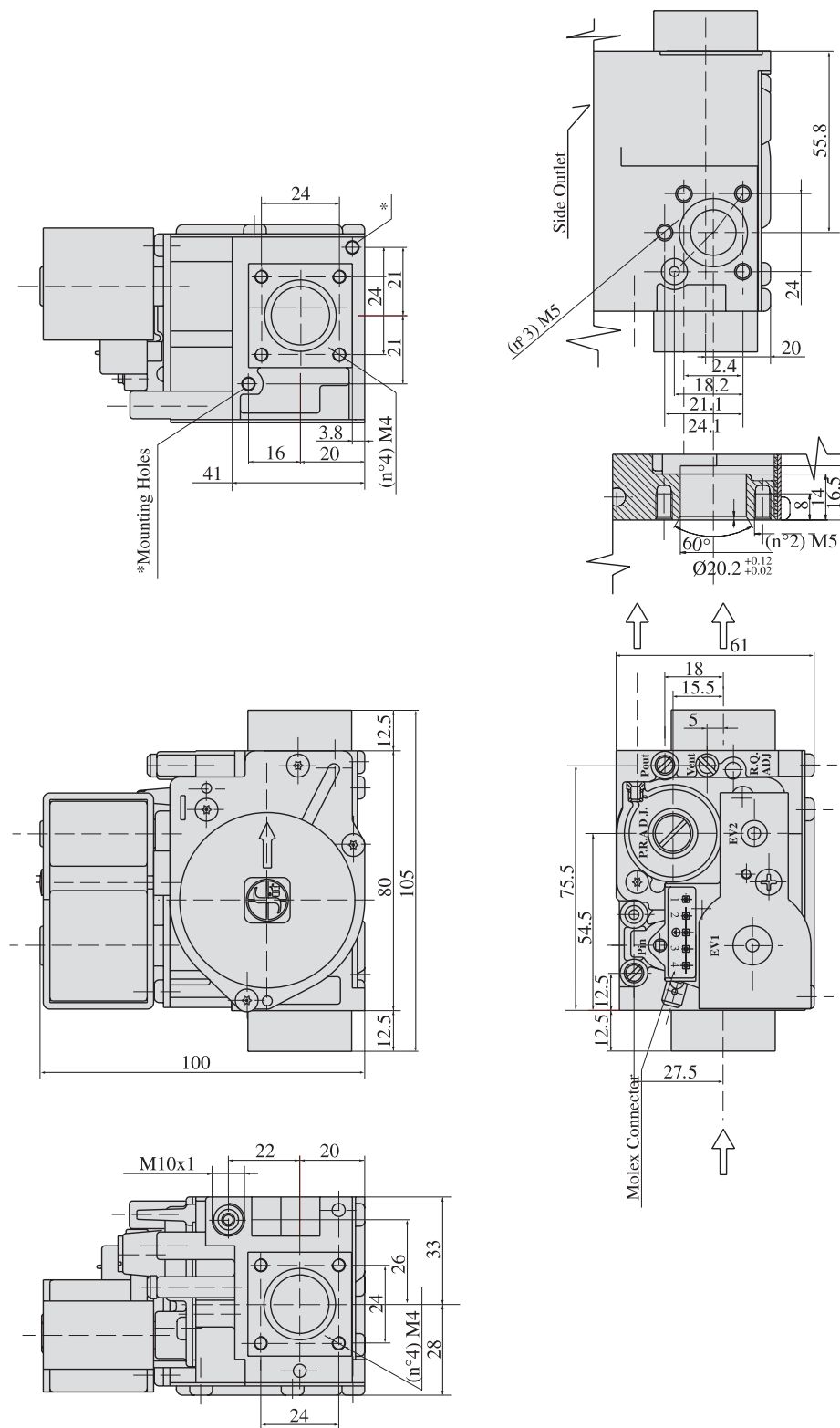

NOTE: All the dimensions are expressed in millimeters.



SITGroup

SIT La Precisa S.p.A.

Viale dell'Industria 31-33

35129 PADOVA - ITALY

Tel. +39/049/829.31.11, Fax +39/049/807.00.93

www.sitgroup.it - e-mail: mkt@sitgroup.it
